

AUTOMATIC POOL CLEANER



The **LCA** controls the cleanliness of the pool bottom by **solenoid valves**. It is an electronic control system that acts on the **nozzles** located at the bottom of the pool. These nozzles rise and cause dirt to rise to the surface, then it is transported to the pool filter through the recirculation circuit of the filtration pump. The LCA includes all the advantages of a equipment electronically controlled. The programming architecture protects the hydraulic circuit from **water hammers** that could damage to PVC pipes, as well as failures in **solenoid valves**. Through active **signaling pilots** you can see the active zones and consequently which pool area is being cleaned.

RLA



Electronic panel for zones control.

Dim: 240x290x110mm

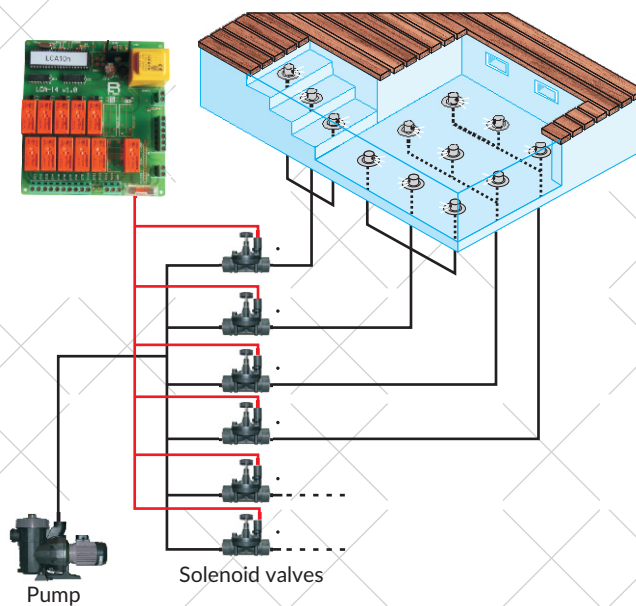

Industrial
d'Automatismes

E.Ribas Industrial d'Automatismes, S.L. - Castelló, 68 - 17485 Vila-sacra (Girona)
Telf. 972.510.015 - ribas@e-ribas.com - www.e-ribas.com